

### Legend

These running slope ranges shall be the starting point. If site conditions warrant, running slopes up to 8.3% or flatter are allowed.

- (S) Indicates Pedestrian Ramp - desired slope between 5.0% minimum and 8.3% maximum in the direction shown.
- (F) Indicates Pedestrian Ramp - desired slope greater than 2.0% and less than 5.0% in the direction shown.
- (R) Curb Ramp
- Turning Space - 4' x 4' min. (5' x 4' min. when constrained). Max 2.0% slope in all directions. Turning Spaces shall be full width of incoming PARs.
- Detectable Warning Plates
- X" Curb height

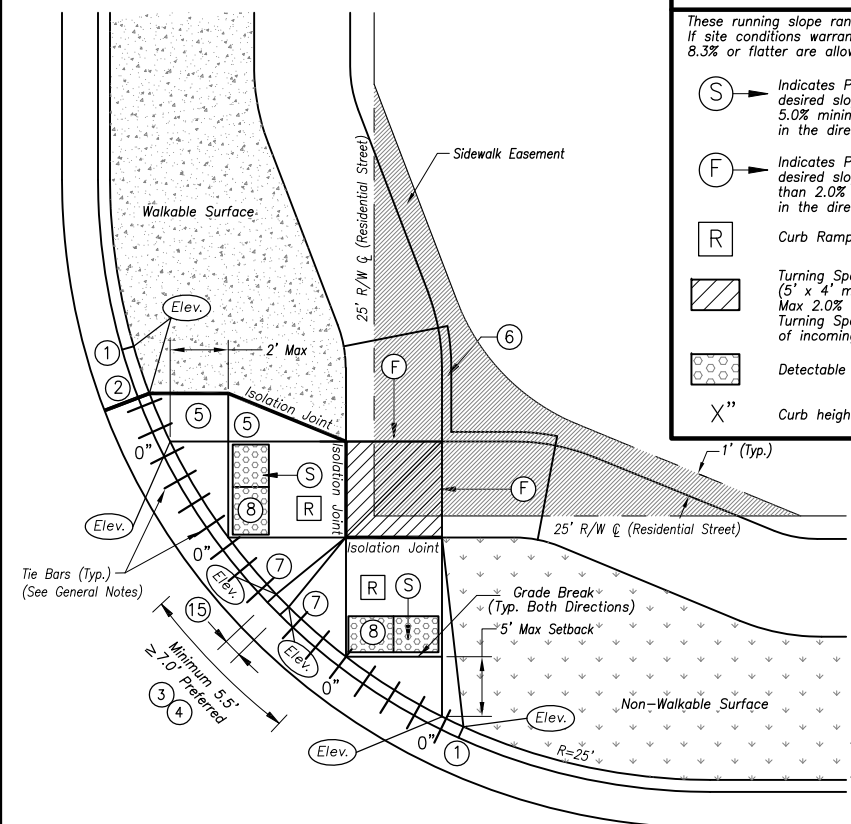

**Combined Directional (Preferred)**

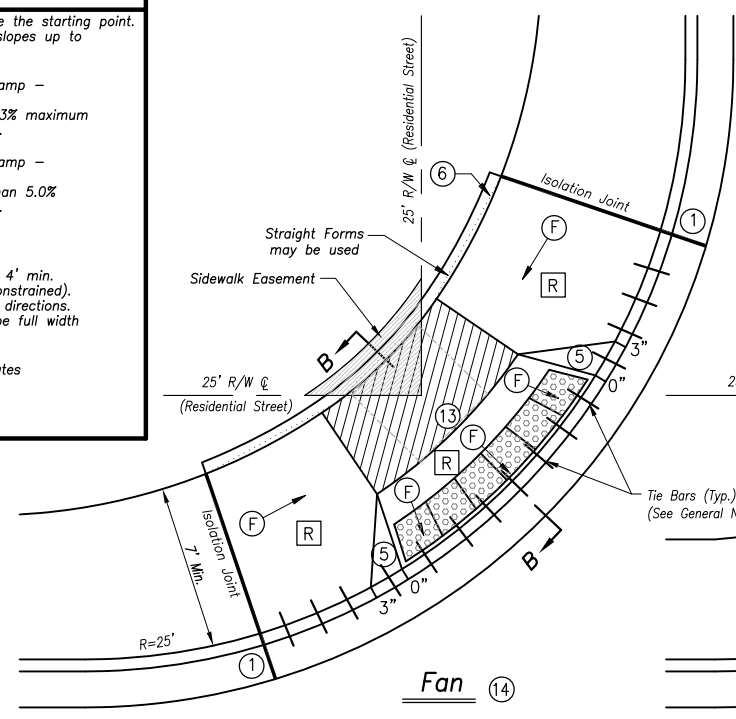

**Fan**

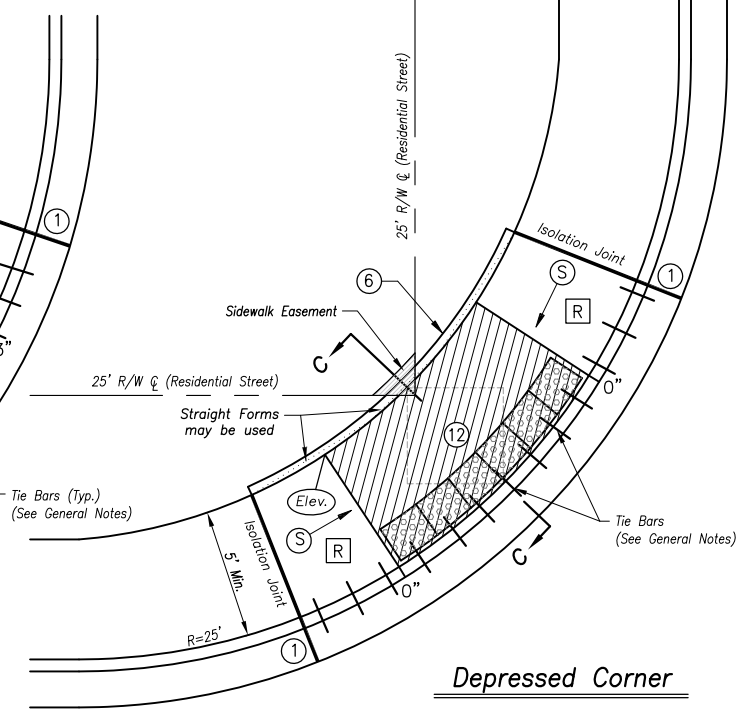

**Depressed Corner**

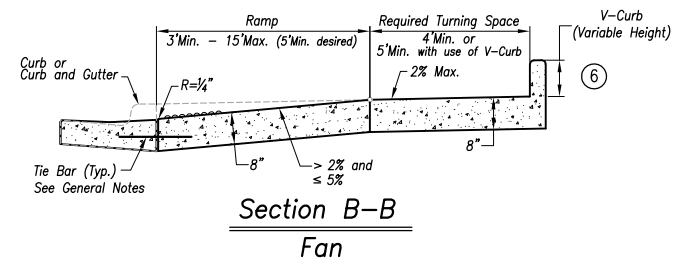

**Section B-B**  
Fan

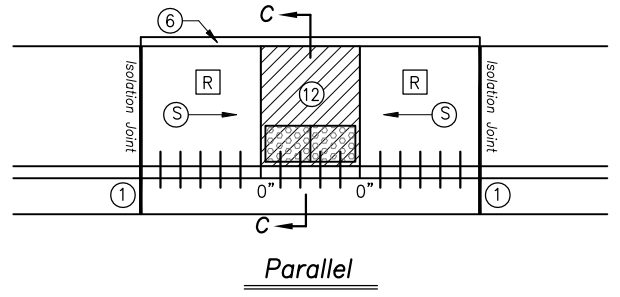

**Section C-C**  
Parallel/Depressed Corner

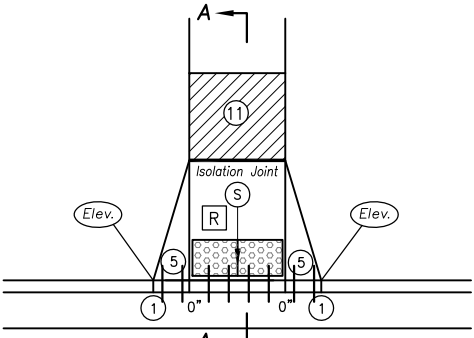

**Section A-A**  
Perpendicular

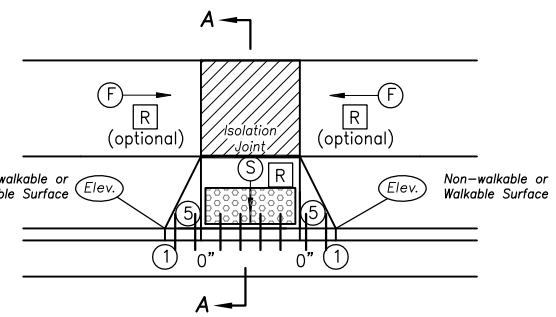

**Section A-A**  
Mid-Block

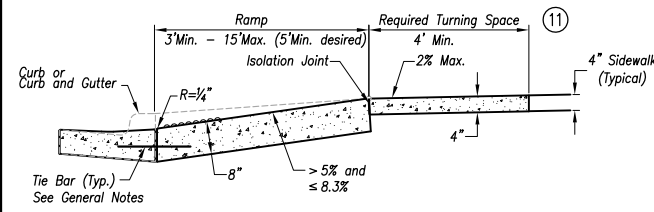

**Section A-A**  
Perpendicular/Mid-Block

- ### Ramp Element Notes:
- 1 Match full curb height.
  - 2 3" high curb when using a 3' long ramp  
4" high curb when using a 4' or longer ramp.
  - 3 3" minimum curb height (5.5' min. distance required between domes);  
4" preferred (7' min. distance required between domes).
  - 4 The divider between the ramps should not be in the path of travel for combined directional ramps. If this occurs, modify the ramp location or switch ramp to a fan/depressed corner.
  - 5 See Sht. 32\_b for flare details.
  - 6 When adjacent to grass, grading shall always be used when feasible. V-curb, if used, shall be placed outside the sidewalk limits when right of way allows. When grading exceeds 4:1 within right of way, use V-curb. When adjacent to parking lots, tapers should be used over V-curb to reduce tripping hazard and facilitate snow and ice removal.
  - 7 8% to 10% walkable flare. If area between ramps is greater than 15 s.f., grass may be installed.
  - 8 Place domes at the back of curb when allowable setback criteria is exceeded.
  - 9 Rectangular detectable warnings may be setback up to 9" from the back of curb with corners set 2" from back of curb. If 9" setback is exceeded, use radial detectable warnings. Radial detectable warnings shall be setback up to 6" maximum from the back of curb.
  - 10 For directional ramps with the detectable warnings placed at the back of curb, the detectable warnings shall cover the entire width of the walk/path.
  - 11 A turning space is not required at the top of a Perpendicular or Standard One-Way Directional curb ramp if there is no change in direction at the top of the ramp.
  - 12 Detectable warnings may be part of the 4' x 4' min. landing area if it is not feasible to construct the landing outside of the detectable warning area.
  - 13 A 7' min top radius grade break required to be constructible.
  - 14 "S" slopes on fans shall only be used when "F" slopes have been evaluated and deemed impractical.
  - 15 6" minimum length. See Detectable Edge with Curb and Gutter detail.

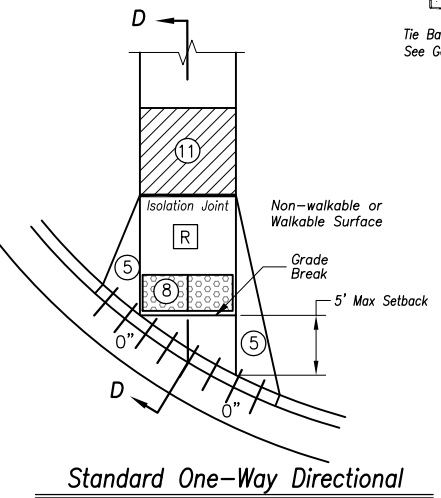

**Section D-D**  
Standard One-Way Directional

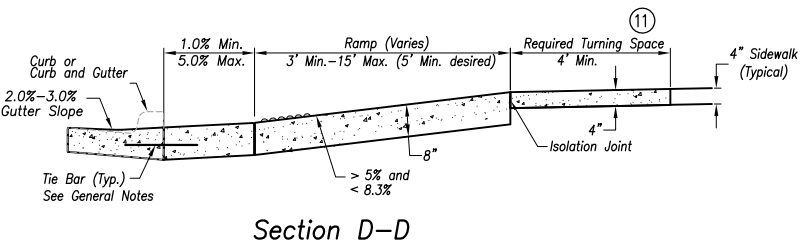

**Section D-D**

- ### General Sidewalk & Sidewalk Ramp Notes:
1. Overland Park Municipal Code (OPMC) and Overland Park Design and Construction Standards Manual (OPDCSM) are incorporated, except as otherwise noted. KCMMBAK Concrete shall be used throughout.
  2. Sidewalk ramp location determined from the intersection of the extension of back of sidewalk and back of curb & gutter.
  3. Positive flow line drainage shall be maintained through the Pedestrian Access Route (PAR). No ponding shall be present in the PAR. Any vertical lip that occurs at the flow line shall not be greater than 1/4 inch.
  4. Turning Spaces shall be located anywhere the PAR changes direction, and if the approaching walk is inverse grade.
  5. The maximum cross slope requirements for perpendicular curb ramps and blended transitions adjacent to pedestrian street crossings are as follows:  
At Yield or Stop Control - 2%;  
Without Yield or Stop Control, or with Traffic Signals - 5%;  
At Midblock - no greater than the street grade.
  6. When not adjacent to pedestrian street crossings, PAR and ramp cross-slope 1% desired, 2% maximum.
  7. Contraction joints shall be constructed along all grade breaks and at the tops of concrete flares adjacent to walkable surfaces.
  8. All grade breaks within the PAR shall be perpendicular to the path of travel.
  9. All ramp types should have a minimum of 3' ramp length.
  10. Detectable warnings shall continuously extend for a minimum of 24" in the path of travel. Detectable warning to cover the entire width of sidewalk and shared-use paths. Arc length of radial detectable warnings should not be greater than 20 feet.
  11. Rectangular detectable warnings shall be setback 2" minimum to 9" maximum from the back of curb. See 9 for information regarding rectangular detectable warning placement. Radial detectable warnings shall be setback 2" minimum to 6" maximum from the back of curb.
  12. Elevations shall be provided at all corners of sidewalk slabs which compose the landings or ramps and at all corners of one additional sidewalk panel along the sidewalk in addition to the points labeled (Elev.) on these details. Slope between these points shall be calculated and shown on the plans. Chord distance from PC & PT to fully depressed curb section of curb return shall be shown on the plans. Slope shall be shown for the existing or proposed edge of pavement where ramps connect.
  13. Longitudinal joint spacing and Landing length to match width of sidewalk (4' Min.).
  14. Isolation joints shall be placed where walk abuts driveways and similar structures, and 250' centers max.
  15. Install 18" tie bars #4 epoxy coated @ 18" o.c. and through wings as shown.
  16. Sidewalk Ramp shall be lengthened as needed to provide compliant slope (8.3% Max.) but need not exceed 15' regardless of resulting slope.
  17. Curb depression at ramp opening shall be staked prior to curb construction.
  18. See Curb Replacement Details for additional requirements.
  19. No casting or utility boxes shall be allowed in ramps or turning spaces. Contractor shall be responsible for adjusting utility boxes and coordinating with utilities to obtain ramp and sidewalk compliance.
  20. Do not scale these drawings for dimensions.

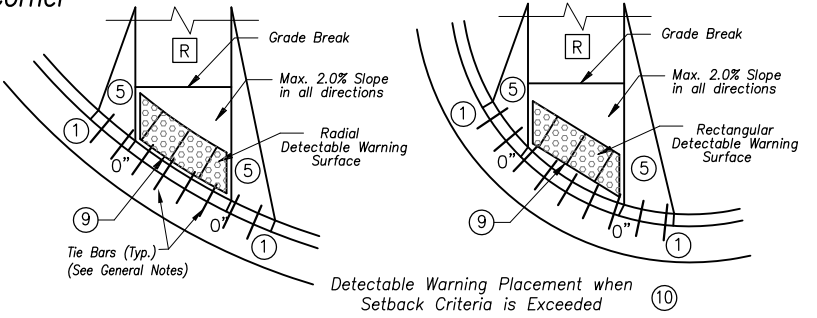

**Detectable Warning Placement when Setback Criteria is Exceeded**

**One-Way Directional with Detectable Warning at Back of Curb**

Year 2018 Edition

REVISIONS:	
Dec. 2006	ADA Compliance
Jan. 2018	Updated ADA Compliance
RELATED ORDINANCES:	
OPMC Title 13	

**OVERLAND PARK**  
KANSAS  
ABOVE AND BEYOND. BY DESIGN.

DEPARTMENT OF PUBLIC WORKS  
STANDARD DETAILS

**SIDEWALK & SIDEWALK RAMP DETAILS**