

V-Curb Adjacent to Landscape
Curb within Sidewalk Limits

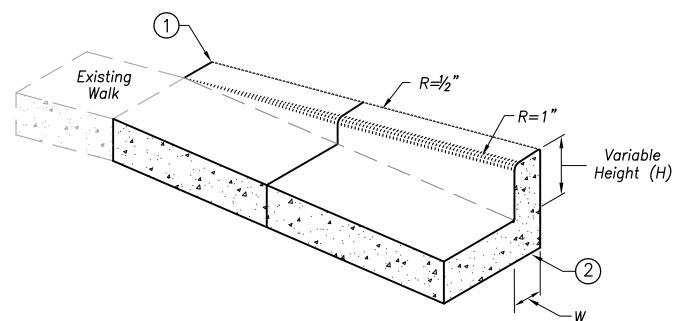

V-Curb Adjacent to Landscape
Curb outside Sidewalk Limits

Concrete Curb Design V	
Curb Height H	Curb Width W
< 6"	4"
6" - 9"	6"
9" - 12"	6" w/ reinforcement

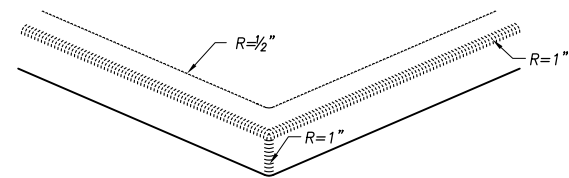

V-Curb Intersection

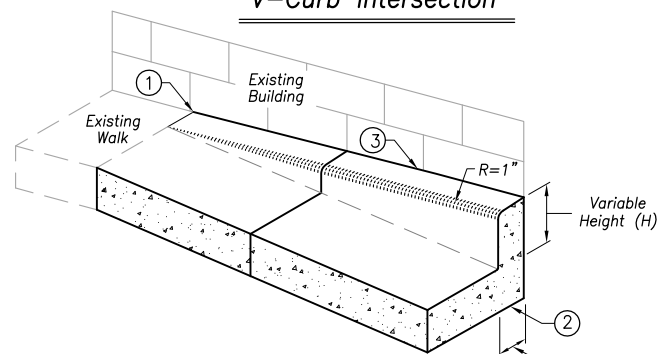

V-Curb Adjacent to Building or Barrier

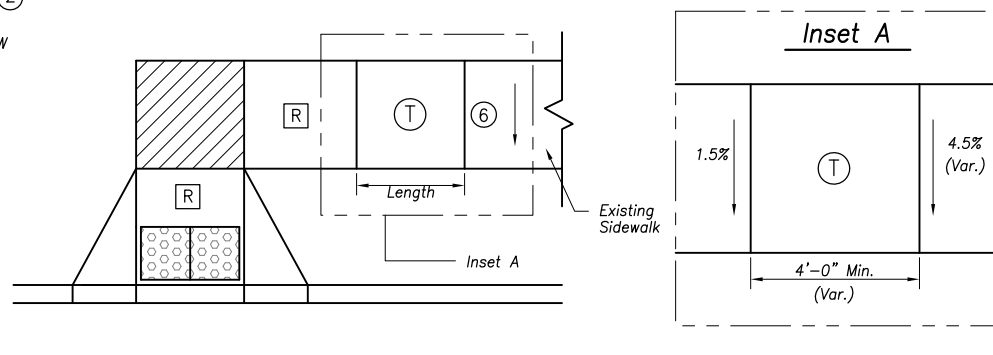

Transition Panel (4) (5)

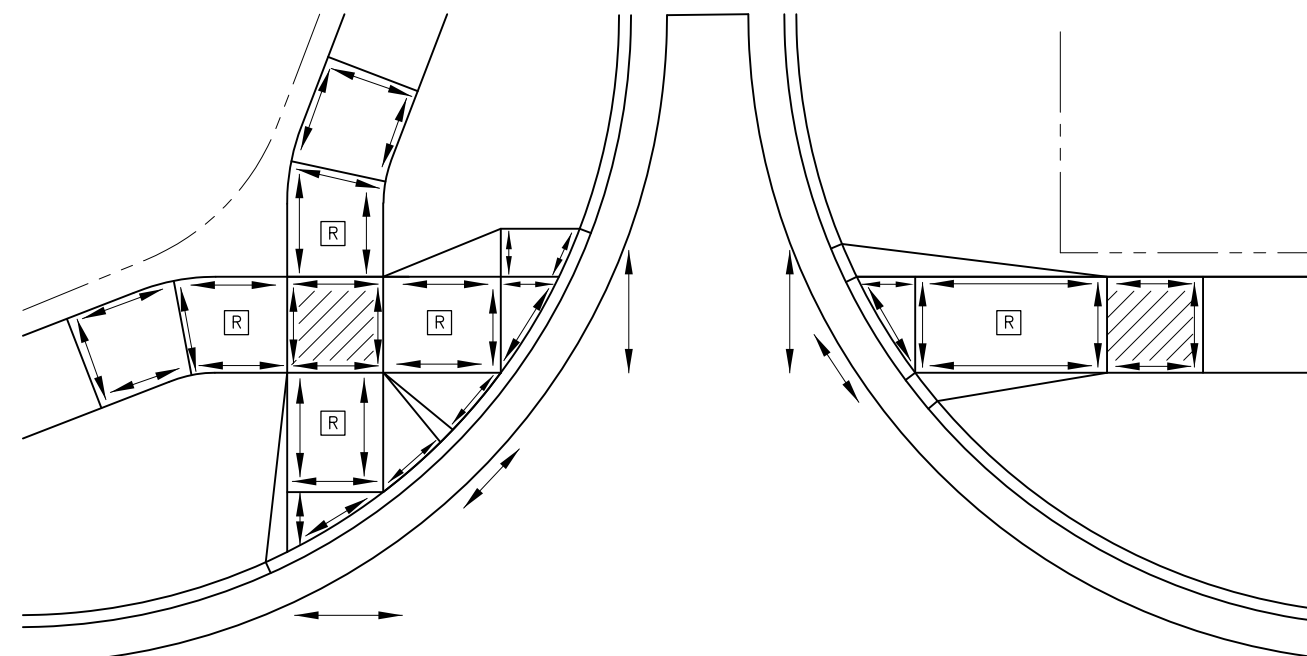

Compliance Reading Locations (*)

* - Measurements shall be taken in accordance with current ADA requirements.

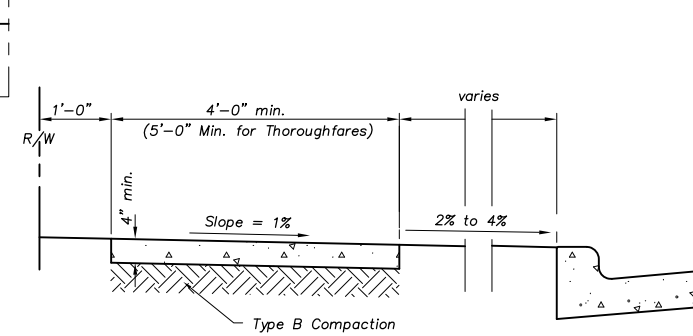

Standard Sidewalk

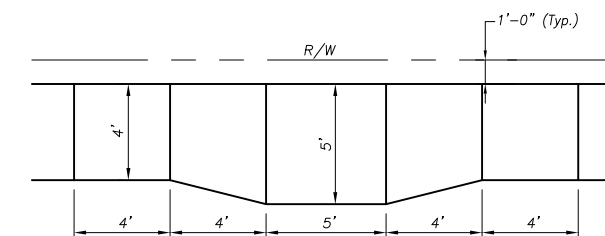

Wheelchair Passing Space

Wheelchair Passing Space to be Constructed where Length of 4' Wide Sidewalk Exceeds 200'.

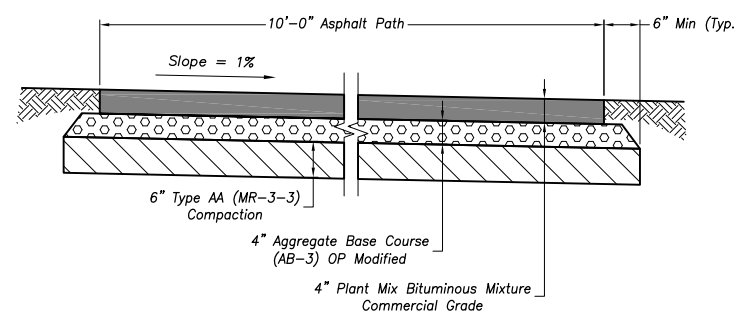

Standard Asphalt Bike/Hike Path

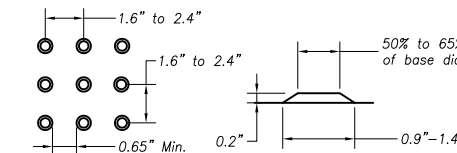

Truncated Dome Dimensions

Ramp Element Notes:

A walkable flare is an 8-10% concrete flare that is required when the flare is adjacent to a walkable surface, or when the pedestrian path of travel of a push button traverses the flare.

Where right-of-way allows, use of V curb should be minimized. Grading adjacent turf or sloping adjacent pavement is preferred, 6:1 grading preferred, 4:1 maximum. On rehabilitation projects if 4:1 is exceeded within right of way, V-curb should be used.

V-curb shall be placed outside the sidewalk limits when right of way allows.

V-curb next to building shall be a 4" width and shall match previous top of sidewalk elevations.

All V-curb contraction joints shall match concrete walk joints.

Some detectable warning products require a concrete border for proper installation. The concrete border should not exceed 2 inches.

- ① End tapers at transition section shall match in place sidewalk grades
- ② All V curb shall match bottom of adjacent walk.
- ③ Edge between new V-curb and in place structure shall be sealed and bond breaker shall be used between existing structure and placed V-curb.
- ④ The max. rate of cross slope transitioning is 1 linear foot of sidewalk per half percent cross slope. When PAR width is greater than 6' or the running slope is greater than 5%, double the calculated transition length.
- ⑤ Transition panels are to only be used after the ramp.
- ⑥ Existing cross slope.

Cast Iron Detectable Warning Plate Notes:

- 1. See approved Material List for pre-approved products.
- 2. Detectable Warning Plates placed radially behind the curb shall be Radius Plates.
- 3. Detectable Warning Plates shall be installed per manufacturer's recommendations.
- 4. Detectable Warning Surface to extend a minimum of 2' in direction of travel.

Sidewalk Ramp Elements General Requirements:

RAMP (Required to transition elevation): Max Running Slope - 8.33%
Max Cross Slope - 2% (1% preferred)
Min Width - 4'

TURNING SPACE (Required to change direction of travel): Max Running Slope - 2%
Max Cross Slope - 2% (1% preferred)
Min Width - 4'

DETECTABLE WARNING SURFACE: Width equals Ramp Opening Width @ Curb
Min Length - 2'
Domes should be aligned with direction of travel.

Legend

- (R) Curb Ramp
- (T) Transition panel(s) - to be used for transitioning the cross-slope of a ramp to the existing walk cross-slope. Rate of transition should be 0.5% per 1 linear foot of walk. See this sheet for additional information.
- Turning Space - 4' x 4' min. (5' x 4' min. when constrained). Max 2.0% slope in all directions. Turning Spaces shall be full width of incoming PARs
- Detectable Warning Plates

REVISIONS:	
Dec. 2006	ADA Compliance
Jan. 2018	Updated ADA Compliance
RELATED ORDINANCES:	
OPMC Title 13	

Year 2018 Edition

OVERLAND PARK
KANSAS
ABOVE AND BEYOND. BY DESIGN.

DEPARTMENT OF PUBLIC WORKS
STANDARD DETAILS

SIDEWALK & SIDEWALK RAMP DETAILS

DATE: 01/20/04 SHEET: 32 c